

# TTC Series

Up to 6 LPM Free Flow

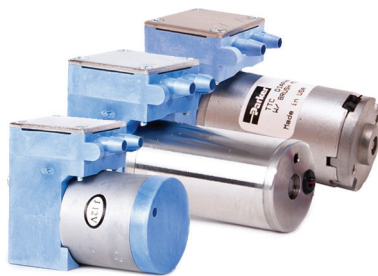

## Miniature Diaphragm Pumps (air/gas)

TTC Miniature Diaphragm Pumps are a series of brush and brushless DC motor driven pumps, which are tailored to meet specific application performance requirements. An innovative compact design incorporates leading edge technologies that allow them to operate more efficiently than existing pump designs. TTC Pumps offer multiple component configurations for use in either vacuum, pressure, or alternating vacuum and pressure operations. TTC Series is best for compact and low pressure applications that require high efficiency.

### Features:

- TTC Series' innovative and efficient design pushes the performance envelope in a lightweight, compact size which allows it to operate at the highest performance/size ratio.
- Highest efficiency in class. The TTC supports low power for portable and battery powered instruments.
- Using our proprietary advanced diaphragm elastomer and superior brushless motor design sets the highest benchmark for service-free operation that exceeds 10,000 hours.
- Incorporating the lightweight EZ Mount accessory facilitates simple system assembly while dampening vibration and reducing noise levels.
- RoHS compliant. 

### Typical Applications

- Gas Analysis
- Anesthesia Monitors
- Compression Therapy
- CO<sub>2</sub> Monitors
- Wound Therapy
- Trace Detection
- Medical/Training Mannequins
- Degassing

## Product Specifications\*

### Physical Properties

<b>Operating Environment<sup>1</sup>:</b>
41 to 122°F (5 to 50°C)
<b>Storage Environment:</b>
-4 to 212°F (-20 to 100°C)
<b>Media:</b>
Air, Argon, Helium, Nitrogen, Oxygen, and other non-reacting gases
<b>Humidity:</b>
0 – 80% Relative Humidity
<b>Noise Level<sup>2</sup>:</b>
As low as 45 dB @ 12 in (30 cm)
<i>Muffler recommended for additional noise reduction (see accessories)</i>
<b>Pump Assembly Rated Life<sup>3</sup>:</b>
PMDC Iron Core Brush - 3,000 hrs
Brushless Slotted - 10,000 hrs
Brushless Slotless - 10,000 hrs
<b>Weight:</b>
7.2 oz. (206 g) PMDC Iron Core Brush
5.0 oz. (142 g) Brushless Slotted
7.7 oz. (218 g) Brushless Slotless

### Electrical

<b>Motor Type (DC):</b>
PMDC Iron Core Brush, Brushless Slotted, Brushless Slotless
<b>Nominal Motor Voltages<sup>4</sup>:</b>
6, 12, or 24 VDC
<i>Other voltages available upon request</i>
<b>Electrical Termination:</b>
PMDC Iron Core Brush - 22 AWG Wire Leads, Length 10" (254 mm)
Brushless Slotted Motor - 22 AWG Wire Leads, Length 20" (508 mm)
Brushless Slotless - 22 AWG Wire Leads, Length 20" (508 mm)
<b>Current Range<sup>5</sup>:</b>
300-800 mA

### Wetted Materials

<b>Diaphragm:</b>	<b>Pump Head:</b>
EPDM, AEPDM, FKM	Vectra (Liquid Crystal Polymer)
<b>Valves &amp; Gaskets:</b>	<b>Valve Cover:</b>
EPDM, FKM	303 Stainless Steel

### Pneumatic

<b>Head Configuration:</b>
Single
<b>Maximum Unrestricted Flow:</b>
6 LPM
<b>Pressure Range:</b>
0 - 10 psig (0 - 0.7 bar)
<b>Vacuum Range:</b>
0 - 16 in Hg (0 - 406 mm Hg)
<b>Filtration:</b>
40 microns - recommended
<b>Efficiency at Free Flow<sup>6</sup></b>
PMDC Iron Core Brush: 0.8 LPM/Watt (PN: TS008-13)
Brushless Slotted: 1.4 LPM/Watt (PN: TS003-11)
Brushless Slotless: 1.8 LPM/Watt (PN: TS001-13)

\* See Appendix A for details.

## Performance Specifications

## TTC - Brushless Slotted Motor

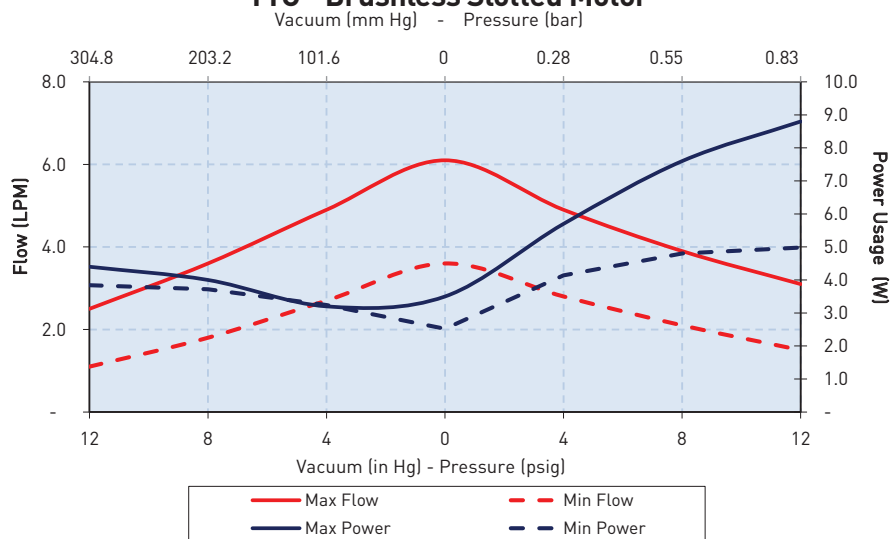

## TTC - Brushless Slotless Motor

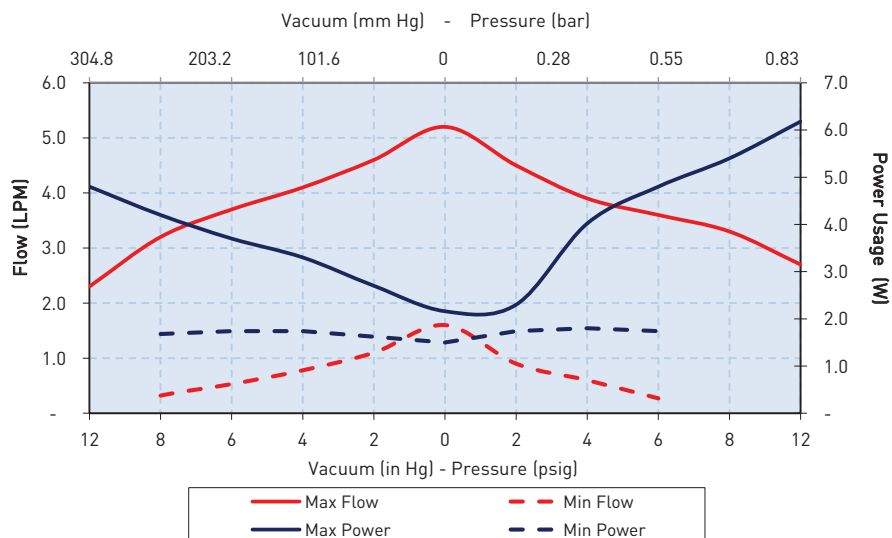

The above graph represents an example of performance for the pumps series handling air at 800 feet (244m) above sea level at 75°F (24°C). Performance will vary depending on barometric pressure and media temperature. Curves are representative of standard pump configurations. Pump configurations could be customized for higher or lower flows, depending on specific customer requirements.

Please contact Parker Precision Fluidics Applications Engineering for other considerations.

# TTC Series

## Miniature Diaphragm Pumps (air/gas)

### Sizing and Selection continued

<b>TTC Series</b>	PMDC Iron Core Brush	Brushless Slotted Motor	Brushless Slotless Motor
-------------------	----------------------	-------------------------	--------------------------

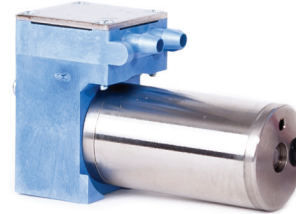
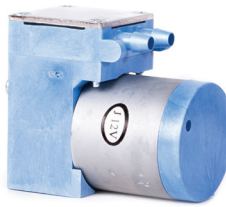
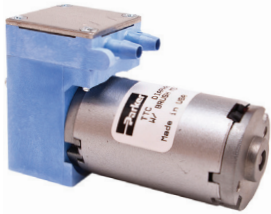

	PMDC Iron Core Brush	Brushless Slotted Motor	Brushless Slotless Motor
<b>Efficiency<sup>1</sup></b>	Good	Better - Up to 60% motor efficiency at low loads	Best Up to 75% motor efficiency
<b>Life<sup>2</sup></b>	Good - 3,000 hrs	Best - 10,000 hrs	Best - 10,000 hrs
<b>Cost</b>	Best	Better	Premium
<b>Noise</b>	Good	Better	Best

#### Mounting Guidelines:

- Bracket options available for mounting consideration (See *EZ Mount catalog pages*).
- Hole in the center of the bottom of housing is for manufacturing only—not to be used for mounting.
- Mounting holes are drilled for #6-20 self-tapping screws with 1/4" (6 mm) thread engagement, torque to 4 in-lbs (0.45 N-m).

#### Port Connections:

- Barbs are sized for 1/8" (3 mm) ID tubing, 70-80 durometer recommended.
- Flow direction is marked on the pump head with arrows.

## Mechanical Integration

### Dimensions

PMDC Iron Core Brush

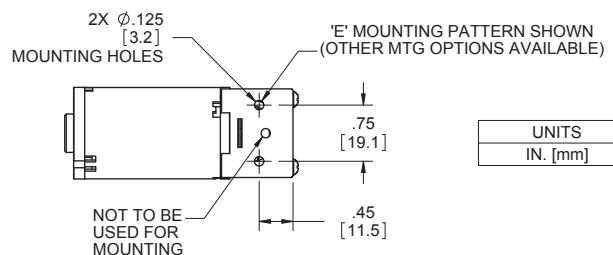
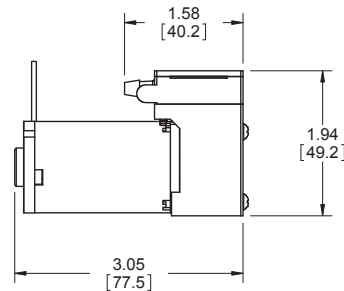
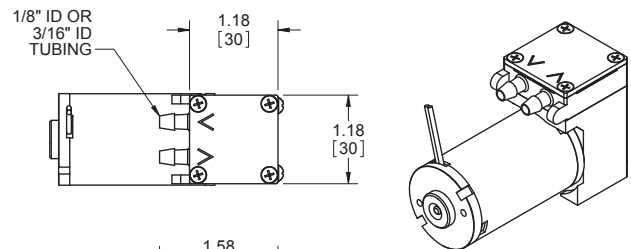
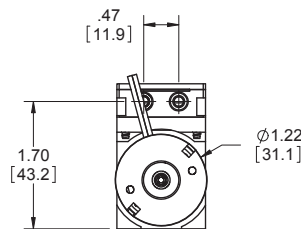

UNITS
IN. [mm]



# Miniature Diaphragm Pumps (air/gas)

# TTC Series

Brushless Slotted Motor

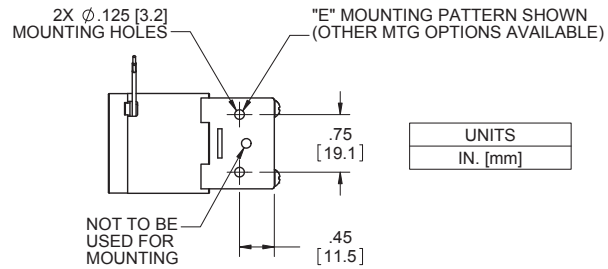
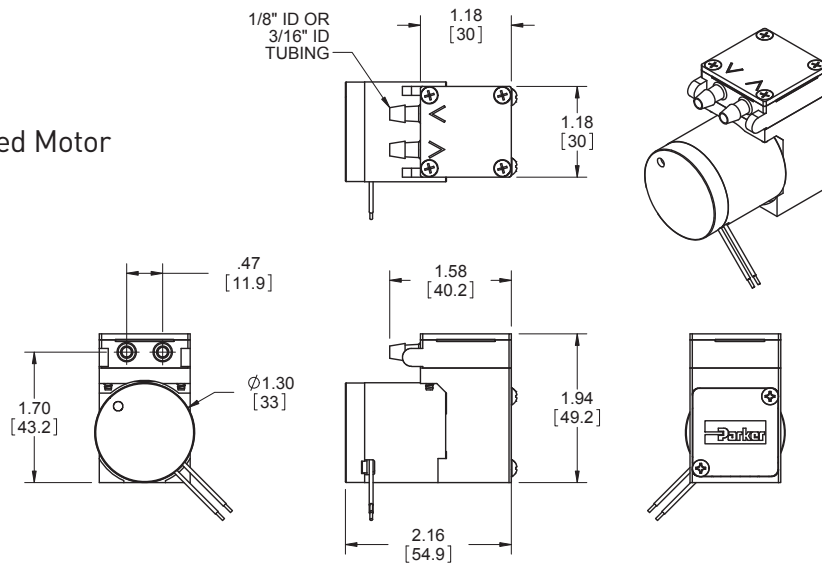

Brushless Slotless Motor

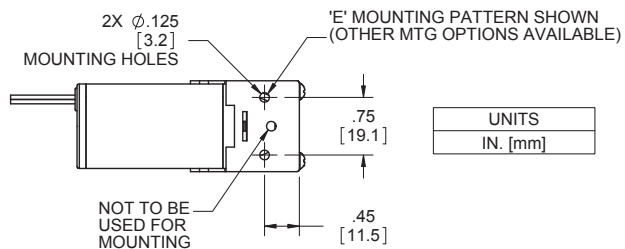
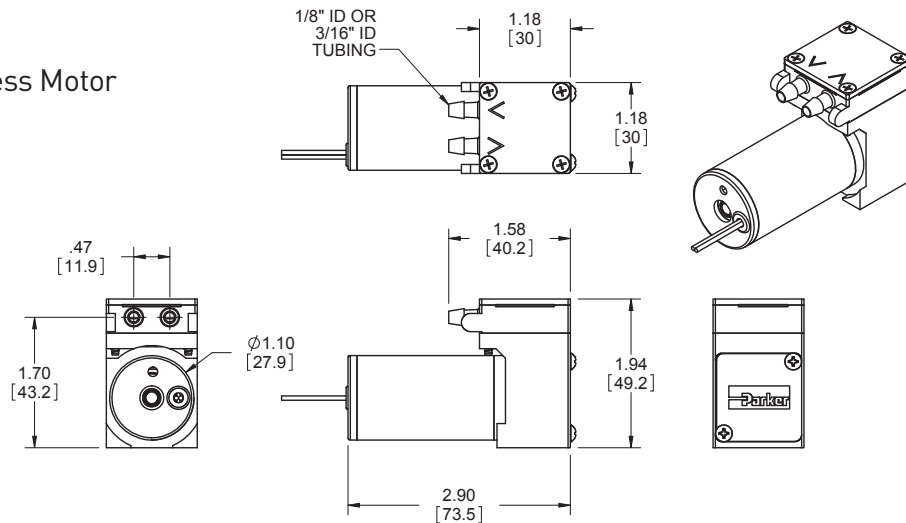

## TTC Series

## Miniature Diaphragm Pumps (air/gas)

### Electrical Integration and Motor Control

#### PMDC Iron Core Brush Motor

2 Wire	Red (+), Black (-)
Wire specification	22 AWG, Insulation OD 0.051 in (1.30 mm), 10" (254 mm) Wire Leads

#### Brushless Motor Control Options

2 Wire	Red (+), Black (-)
3 Wire (Speed Control)	Red (+), Black (-), White (PWM) or Yellow (Analog)
4 Wire (Speed Control & Feedback)	Red(+), Black (-), White (PWM) or Yellow (Analog), Blue (Tachometer)
Wire specification	22 AWG, Insulation OD 0.051 in (1.30 mm), 20" (508 mm) Wire Leads

#### Other Motor Control Considerations

The drive electronics for the BLDC motors are integrated into the motor itself, all that is needed is a power supply with the sufficient voltage and current.

#### Key Things to Remember

The pump is not a pressure holding device. An external check valve is recommended, if there is a pressure holding requirement.

Pump orientation does not affect performance or life.

### Pulse Width Modulation (PWM)

**Pulse-width modulation** is a commonly used technique for controlling DC motors.

The average value of the voltage fed to the motor is controlled by turning a switch between the voltage supply and the motor on-and-off at a fast pace. The longer the switch is on compared to the off time, the higher the power supplied to the motor.

The PWM switching frequency varies for different types of devices, and is selected based on how it affects the device. For example, some applications require a faster switching frequency to prevent audible noise or electrical noise.

The term duty cycle describes the ratio of on-time to the period (one complete on-and-off cycle). Duty cycle is normally expressed as a percentage of on-time, 100% being full-power and 50% being half-power.

The advantage of PWM is the reduction of power-loss due to switching versus other control methods. Parker Hannifin recommends controlling the pump using 15kHz - 20 kHz frequency range.

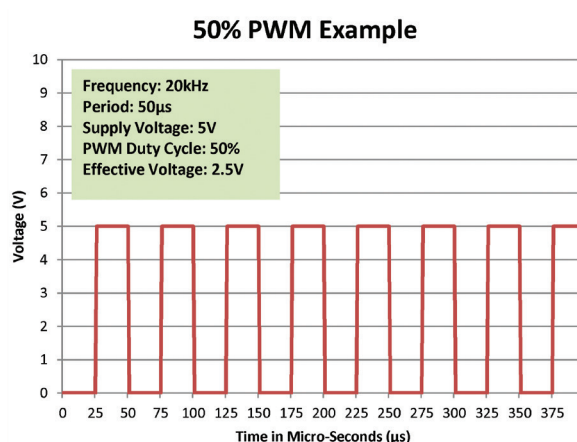
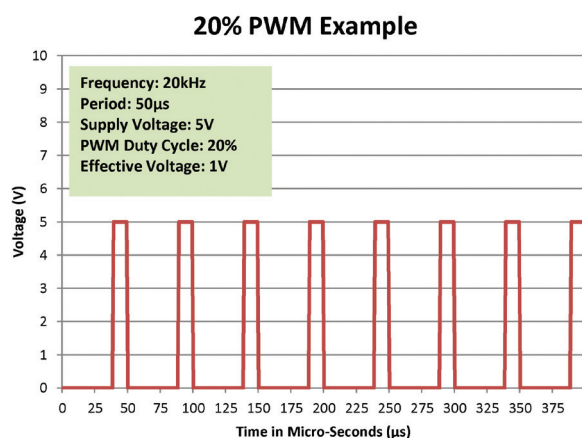

# Typical Flow Diagram

## Air-Over-Liquid Flow Control

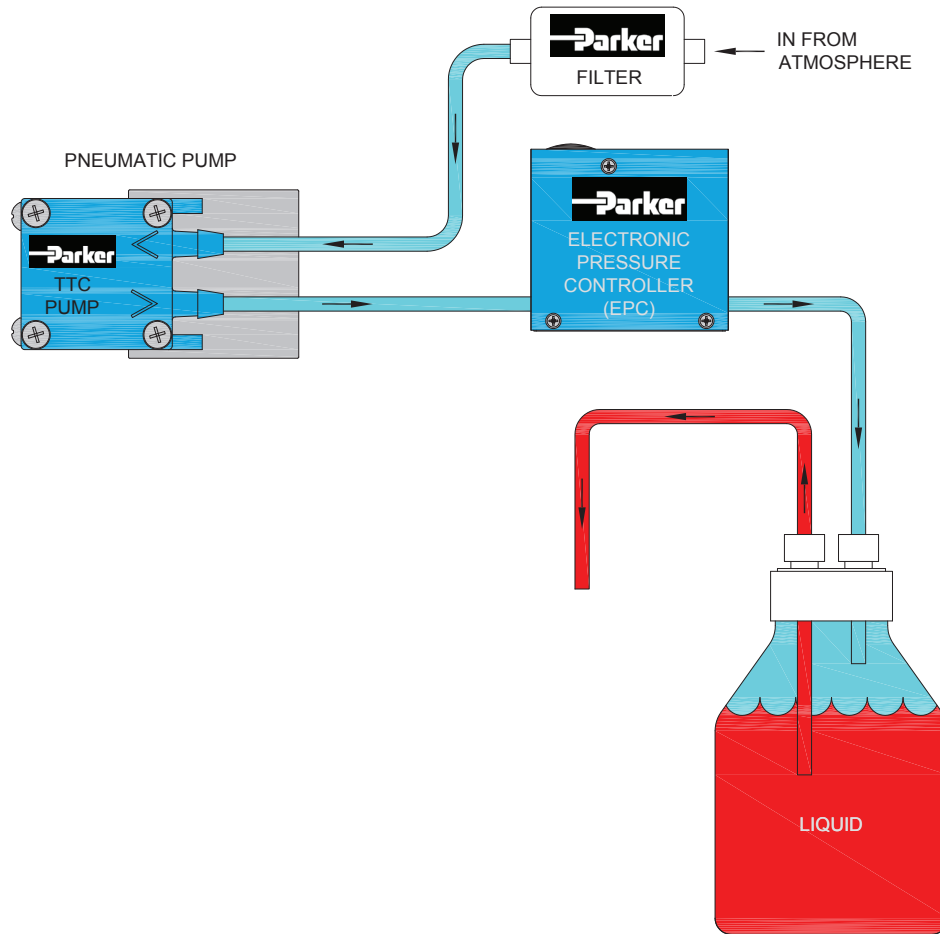

## Accessory Information

Filter-Mufflers also available to assist with filtration and optimize noise reduction.

Part Number: 00492-15  
(Filters to 10 microns)

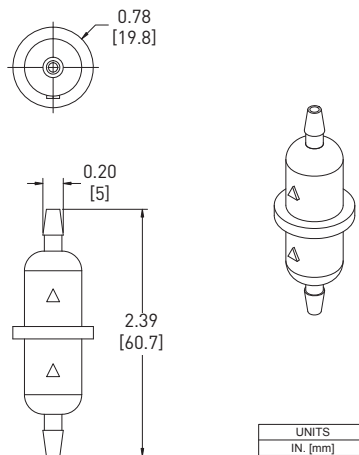

## TTC Series

## Miniature Diaphragm Pumps (air/gas)

### Accessory Information

EZ Mount available

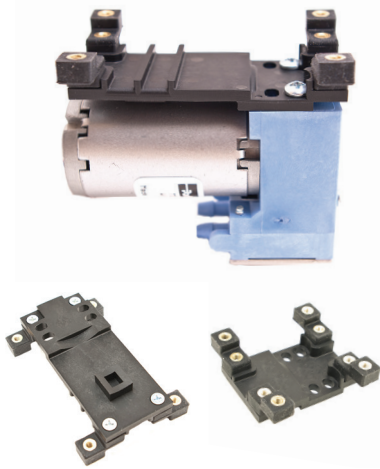

**EZ Mount** provides ease of installation and effective control of vibration transfer. EZ Mount was designed to mount easily to the Precision Fluidic TTC Family of diaphragm pumps.

#### Features

- Isolation feet on the EZ mount can be rotated in any one of three ninety-degree planes and is designed for top-down or bottom-up mounting providing simple installation.
- EZ Mount was designed to minimize weight added to the pump assembly. Approximate weights are: Style A - 0.63 oz (18 g), Style B - 0.71 oz (20 g).
- Effectively absorbs vibration to minimize most vibration-induced noise and vibration transfer into an instrument.
- Designed to keep height and size to a minimum.
- Engineered for Parker TTC pumps to ease integration into your system.

### Physical Properties

#### Operating Environment:

41 - 158°F (5 - 70°C)

#### Humidity:

0 - 95% Relative Humidity

#### Base Plate:

Noryl GTX830

#### Feet:

Silicone

#### Feet Insert:

Brass

#### Hardware:

Zinc-Plated Steel

EZ Mount kits include all necessary hardware and detailed instructions.

Isolation Feet are available in either threaded or thru-hole clearance for standard #4-40 or #6-32 (M3 for clearance hole only) hardware and can be mounted in any of three ninety-degree planes.

### Dimensions

#### Style A - Brushless Slotted Motor

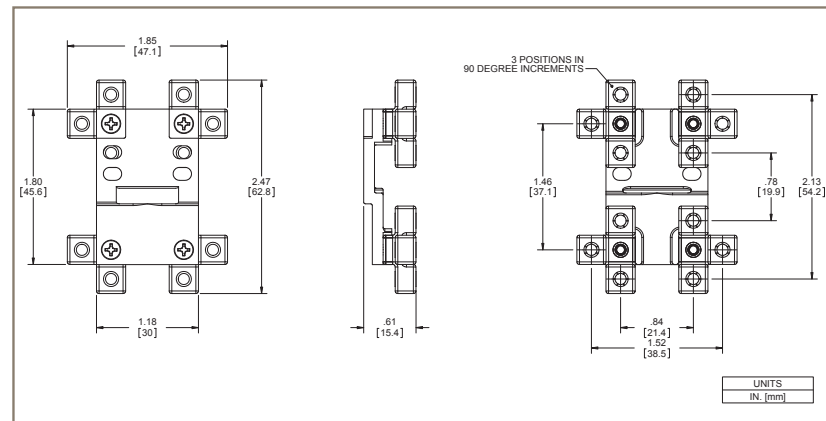

#### Style B - PMDC Iron Core Brush Motor

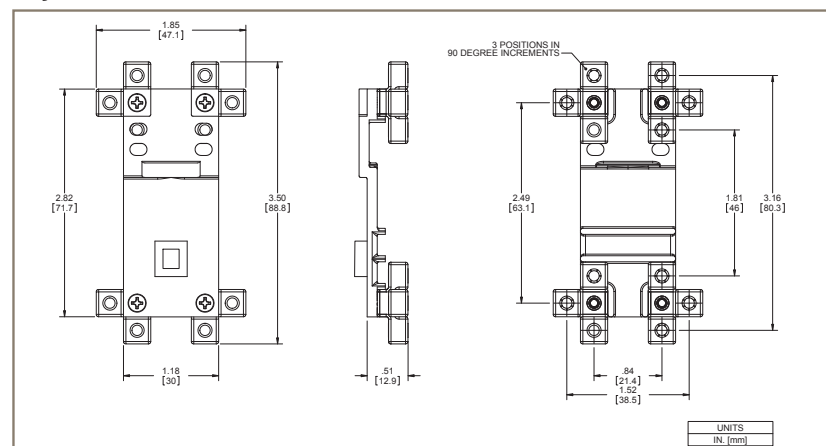

## Chemical Compatibility Chart\*

Chemical	Chemical Compatibility of Wetted Path Materials					
	FKM	EPDM	AEPDM	PTFE	Vectra A130	303 Stainless
Air	1	1	1	1	1	1
Ozone (1000 ppm)	4	4	4	2	2	2
Oxygen	1	1	1	1	1	1
Ethylene (Ethene)	1	4	1	1	3	2
Acetylene	1	1	1	1	1	1
Propane	1	4	4	1	1	1
Methane	1	4	4	1	1	1
Nitrogen	1	1	1	1	1	1
Carbon Dioxide	1	2	2	1	1	1
Halothane (Up to 5%)	1	4	4	1	1	1

\*The above is an Abbreviated Chemical Compatibility Chart. Please consult factory for details.

### Compatibility Legend

- |   |  |
|---|--|
| 1. EXCELLENT<br>Minimal or no effect                            | 3. DOUBTFUL<br>Moderate or severe swelling and loss of physical properties |
| 2. GOOD<br>Possible swelling and/or loss of physical properties | 4. NOT RECOMMENDED<br>Severe effect and should not be considered           |

Note: Consult factory for other gases.

## Ordering Information

### TTC Single Head Pumps - General Purpose

Part No.	Vacuum: LPM @ Load				Free Flow	Pressure: LPM @ Load				Max		Motor Type	PCD*		Wetted Materials
	16 in Hg	12 in Hg	8 in Hg	4 in Hg		4 psig	8 psig	12 psig	16 psig	Vac in Hg	Press psig		VDC	mA	
	406 mm Hg	305 mm Hg	203 mm Hg	102 mm Hg	0	276 mbar	552 mbar	827 mbar	1103 mbar						Diaphragm, Valves, Gasket
TS002-12		2.5	3.6	5.9	6.1					16.0		Brushless Slotted	12	520	EPDM
TS001-13					6.0	4.9	3.9	3.1		16.0		Brushless Slotted	12	735	EPDM
TS008-13					6.0	4.7	3.9	3.2		16.0		PMDC Brush	12	660	EPDM
TS008-12		2.5	3.6	4.8	5.8					16.0		PMDC Brush	12	500	EPDM
TS005-13					5.2	3.9	3.3	2.7		16.0		Brushless Slotless	12	515	EPDM
TS006-12		2.3	3.2	4.1	5.1					16.0		Brushless Slotless	12	400	EPDM
TS003-11		1.1	1.8	2.7	3.6	2.8	2.1	1.5		12.0	16.0	Brushless Slotted	12	415	EPDM
TS007-11			0.3	0.8	1.6	0.6	0.3*			16.0		Brushless Slotless	12	150	EPDM

Note: The Ordering Information Section includes a few selected part numbers for the product line. Other performances and configurations are available. Please contact your Sales Representative or an Application Engineer to discuss your application needs.

\*PCD: Peak Current Draw



## TTC Series

## Miniature Diaphragm Pumps (air/gas)

### Ordering Information

#### Accessory Information

Part No.	Filtering Level (Micron)	Filter Area	Internal Volume	Operating Limitations:			Wetted Materials
00492-15	10	1.71 in <sup>2</sup> (11 cm <sup>2</sup> )	0.24 in <sup>3</sup> (3.9 cm <sup>3</sup> )	Max Temperature 80°C	Min Temperature 32°C	Max Pressure 65 PSI (4.48 bar)	Polypropylene
Filter-Mufflers: To assist with filtration and optimize noise reduction. Tubing: Recommendation 1/8" (3mm) ID.							

#### EZ Mount for TTC Single Head Pump with PMDC Iron Core Brush Motor

Part Number	Style	Description
00329-10-A45S	B	#4-40 Threaded
00329-10-B45S	B	#4 Clearance
00329-10-D45S	B	#6-32 Threaded
00329-10-C45S	B	#6 / M3 Clearance

#### EZ Mount for TTC Single Head Pump with Brushless Slotted Motor

Part Number	Style	Description
00328-10-A45S	A	#4-40 Threaded
00328-10-B45S	A	#4 Clearance
00328-10-D45S	A	#6-32 Threaded
00328-10-C45S	A	#6 / M3 Clearance

#### EZ Mount for TTC Single Head Pump with Brushless Slotless Motor

Part Number	Style	Description
01074-10-A45S	B	#4-40 Threaded
01074-10-B45S	B	#4 Clearance
01074-10-D45S	B	#6-32 Threaded
01074-10-C45S	B	#6 / M3 Clearance

Please click on the Order On-line button below (or go to [www.parker.com/precisionfluidics/ttc](http://www.parker.com/precisionfluidics/ttc)) to configure the TTC Miniature Diaphragm Pump in your application.

Serviceable – PPF products are designed for use through the rated life and Parker does not sell replacement parts, nor is it recommended to service these in the field

Note: In addition to Parker's innovative and flexible pump designs, we offer applications engineering expertise to our customers in order to configure and recommend the optimal pump for the application. Contact Parker Applications Engineering to discuss and configure alternate pump configurations to meet your specific application requirements. Providing information on the following requirements will assist us in developing an optimal solution for your application:

- Noise
- Operating Pressure / Vacuum
- Power Consumption
- Life Requirement
- Function in the Application
- Size
- Motor Control
- Media
- Voltage



## Appendix A

All performance data is typical based on standard conditions: 70°F and 14.7 psia (21°C and 1 bar).

1. Duty Dependent. For operation above 122°F (50°C) consult factory
2. Noise is dependent on the configuration and operation of the pump in the application. Parker has the ability to tailor the pump configuration when noise is a critical criterion in the effort to meet the performance requirements of the application. Noise level is tested to Parker protocol P-105.
3. Life rating can vary depending on application and operating conditions.
4. Custom motor options available. Custom motors may require a significant application potential. The standard motors can be configured with a special winding to meet a particular operation point at a specified voltage
5. Current range is dependent on motor type, voltage, pressure/vacuum and flow requirement. Lower levels possible depending on application.
6. Pump efficiency is a measure of the flow rate generated per unit of power consumed. Efficiency may change dependent on application and operating condition at free flow.

